



**UPS6V-2 Battery Supply and Charger**

**Operations Manual**

**Version 1.1**

**13 May 2016**



**UPS6V-2**



## Contents

1	Introduction .....	3
1.1	Overview .....	3
1.2	Detailed Description .....	3
2	Electrical Specifications .....	4
3	Safety .....	5
3.1	Battery Care.....	5
3.2	RoHS (Restriction of the use of certain Hazardous Substances) .....	5
3.3	FCC Part 15 .....	5
4	Power Connections .....	5
4.1	Input Power Connection .....	5
4.2	Output Power Connection.....	6
4.3	Wrong Connections .....	6
5	Getting Started Setup .....	7
6	Connectors, LEDs, and Switch .....	8
7	Mechanical Dimensions.....	9



## 1 Introduction

### 1.1 Overview

The Valon Technology UPS6V-2 is designed to be a battery pack for all Valon Technology products. The battery pack is intended for portable operation when an ac power supply is not available. The UPS6V-2 can also operate as an uninterruptable power supply (UPS) when connected to a power source providing, automatic switch over to battery power.

### 1.2 Detailed Description

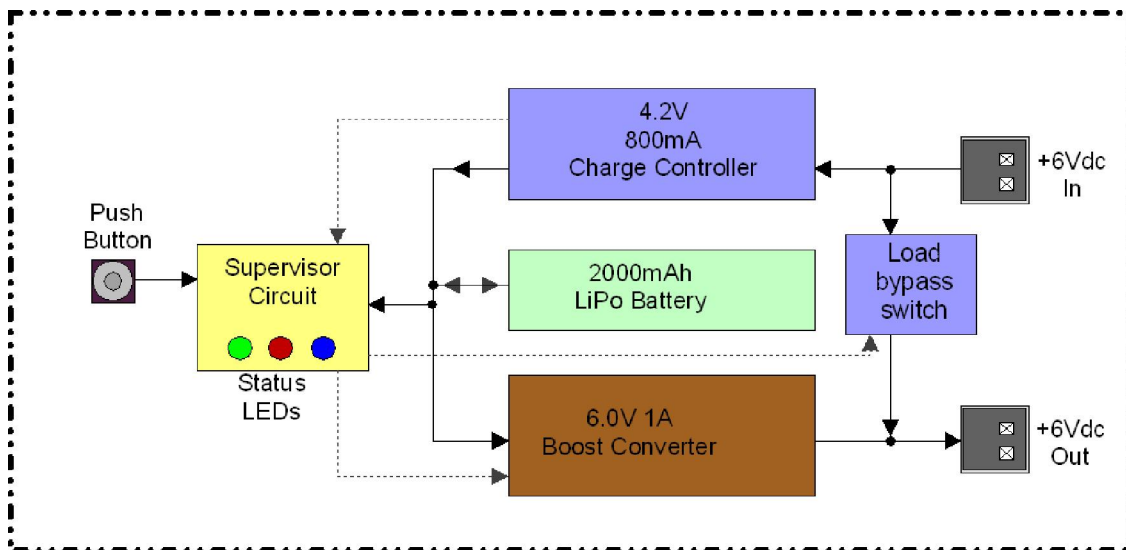

Figure 1 Block Diagram

**Figure 1** shows a block diagram of the UPS6V-2 system topology. The major elements are the single-cell 2000mAh lithium polymer battery, the battery charger circuit, the 6.0V 1A boost converter, the load bypass switch, and the supervisor circuit. The enclosure is a rugged CNC machined aluminum enclosure with an anti-corrosion finish.

The 2000mAh battery is user replaceable and provides up to two hours of use for a Valon 5009 Dual Frequency Synthesizer module with both sources enabled. Much longer battery life can be had with using only one source and even longer with one source and a Valon 5008 Dual Frequency Synthesizer module. The battery is protected from under voltage, over current, and over temperature.

The charger circuit monitors the battery voltage and incoming charging voltage to ensure safe operation. The battery is charged in three phases: Conditioning, constant current, and constant voltage. The phase is determined by the state of the battery. Although intended for 6.0V input, the battery charging can take place with an input as low as 4.5V.



The boost converter maintains a 6.0V output from the 3V lithium battery. The boost converter operates at 2.4MHz and provides a well filtered output with minimal switching noise. The boost converter can provide up to 1.25A to the load and is short circuit protected.

The load bypass switch is power MOSFET that sends the 6V input current directly to the output when the 6V input is present. If the 6V input is not present, then the load bypass switch turns off while the boost converter turns on and provides the 6V output.

If the input voltage falls below the low-voltage threshold, the load bypass switch turns off and the boost converter will turn on. When the voltage rises above the low-voltage threshold, the boost converter will turn back off and the load switch will turn on to provide current directly from the power source to the load.

The supervisor circuit contains the switch threshold voltage sensors and the LED status monitors. The supervisor circuit determines whether or not the boost converter will turn on if the input voltage is not present. The push-button switch operation toggles between battery power on, or battery off. With no input voltage present, the push-button switch can toggle the boost converter to be on. Then when the dc input is applied, the boost converter will turn off and the input power will go directly to the load and the battery charging circuit. If the input power is removed again, the boost converter will automatically take over and supply energy from the battery to the load. Pressing the push-button one more time will toggle the output to off.

## 2 Electrical Specifications

<b>Input Voltage Range</b>	Absolute Max Operational Max Operational Min	+10V, -10V +6.5 charging and load connected +4.5V charging only (no load connected)
<b>Output Voltage</b>	<b>Boost converter off</b> <b>Boost converter on</b>	Output voltage will track input voltage ~75mV when input voltage is above low voltage threshold Output voltage will be 6.00V ± 50mV when input voltage is below low-voltage threshold.
<b>Output Voltage Noise</b>		<20mV pk-pk in 0Hz to 100MHz BW 0.5A load
<b>Input Current</b>	Maximum Charge Maximum Current Charging with Load No load Boost off	800mA No external load 2.05A < 10mA (battery fully charged)
<b>Low Voltage Threshold</b>		3V
<b>DC Input and Output Connectors</b>		<b>Hirose DF3A-2P-2DS</b> Mates with Hirose DF3-2S-2C plug and pre-crimped wire H2BXT-10112-R4 (red) and H2BXT-10112-B4 (black). 20" dc cable s supplied with synthesizer, additional cables available.
<b>Output Current</b>		<b>1.25A max</b>
<b>Battery Capacity</b>		0.5Amps output (6V) for ~ 2hours
<b>Operating Temperature</b>		



Charging	0~40 ° C
Discharging	0~60 ° C
Storage short term	-20 ~+45 ° C
Long term storage	20 ° ± 5 ° C
<b>Battery</b>	Single cell (3.7V) Lithium Polymer 2000mAh Mikoe 1120 <40mg.
<b>Battery Life</b>	>300 charge cycles
<b>Self-discharge rate</b>	>90% capacity after 30days at 20±5°C

### 3 Safety

#### 3.1 Battery Care

The UPS6V-2 contains a single cell lithium-ion polymer rechargeable battery. LIP batteries can be dangerous if mishandled. Do not open the case except to replace the battery. Replace only with the recommended replacement battery. Do not cut or pierce the battery. Do not unwrap the battery covering or attempt to remove the protection circuit. Dispose of the battery in a safe and approved way. Valon Technology is not responsible for any damage this equipment causes to any other equipment connected to or used with it in any way.

#### 3.2 RoHS (Restriction of the use of certain Hazardous Substances)

With the exception of the battery, the UPS6V-2 module is manufactured using all RoHS compliant components and RoHS compliant printed circuit board processing. The case is manufactured using only aluminum with steel fasteners.

Valon Technology, LLC certifies that the UPS6V-2 is RoHS compliant and conforms with the requirements of EC directive 2002/95/EC (RoHS) by having no intentional addition of Lead (Pb), Cadmium (Cd), Mercury (Hg), Hexavalent Chromium (Cr), Polybrominated Biphenyls (PBB), Polybrominated Diphenyl Ethers (PBDE), and any trace impurities of these substances are below the threshold limits as specified by the RoHS directive, specifically Cr+6, Hg, Pb, PBB, PBDE do not exceed 1000 ppm (0.1%) and Cd does not exceed 100 ppm (0.01%).

#### 3.3 FCC Part 15

The UPS6V-2 is considered an industrial component and is intended to be incorporated into customer supplied equipment and is therefore exempt from FCC Part 15.

## 4 Power Connections

#### 4.1 Input Power Connection

Input Power connections are made to the dc power supply using the supplied Hirose 2-pin plug and 20" pig-tail cable assembly. The optimum input voltage for full performance with a synthesizer or similar Valon load is 6.0 Volts minimum. Make sure the power adapter or power supply can deliver the required current both for the load and the charger. For example, if the load is a 5009 requiring typically 540mA and the battery is being charged, then the power supply or ac adapter must be able to deliver ~1.6Amps.

Do not intentionally apply reverse polarity to the power input connector. However, if you do, no damage will occur and no current will be drawn. Disconnect and examine your connections and reapply power.



It is possible to charge the internal battery from a USB source. However, the USB is barely 5.0V which is acceptable for charging the battery but no load should be connected to the 6.0V output connector while charging from USB. One reason is that the USB may not be able to provide the current required to charge the battery and power the load. Another reason is that the USB power sags considerably when powering external devices and will not meet the 6.0V required by Valon synthesizer products. Finally, Valon Technology will not and does not accept any responsibility for any damage caused to a USB powering device.

## **4.2 Output Power Connection**

The output connector provides an accurate and stable 6.0V whenever the boost converter is on and power is being taken from the battery. When the power is being provided by the external power supply/charger, then the output voltage will be approximately equal to the input voltage minus minimal internal switch losses and cable losses.

The internal load bypass switch circuit will detect the presence of the input voltage and pass that to the output connector. That voltage may not be adequate (<6V) to power a synthesizer. Make sure that power supply output voltage is correct.

## **4.3 Wrong Connections**

There is nothing to prevent connecting the power supply or ac adapter/charger into the 6V OUT connector of the UPS6V-2. Doing so will not damage the power supply or the UPS6V-2. Simply disconnect and reconnect the cable to the correct connectors.

You may make a mistake in reversing the polarity of the external power supply or ac adapter charger. This will not damage the UPS6V-2 or the external power supply. The UPS6V-2 will not draw reverse current from the 6V IN connector.

The only precaution is to avoid the possibility of connecting an external power supply or ac adapter to the 6V OUT connector with reversed polarity. This will draw excessive current from the source and may damage the UPS6V-2. Typically, if the external power supply is current limited to <3A, then no permanent damage will occur.



## 5 Getting Started Setup

The figure below illustrates a typical user setup.

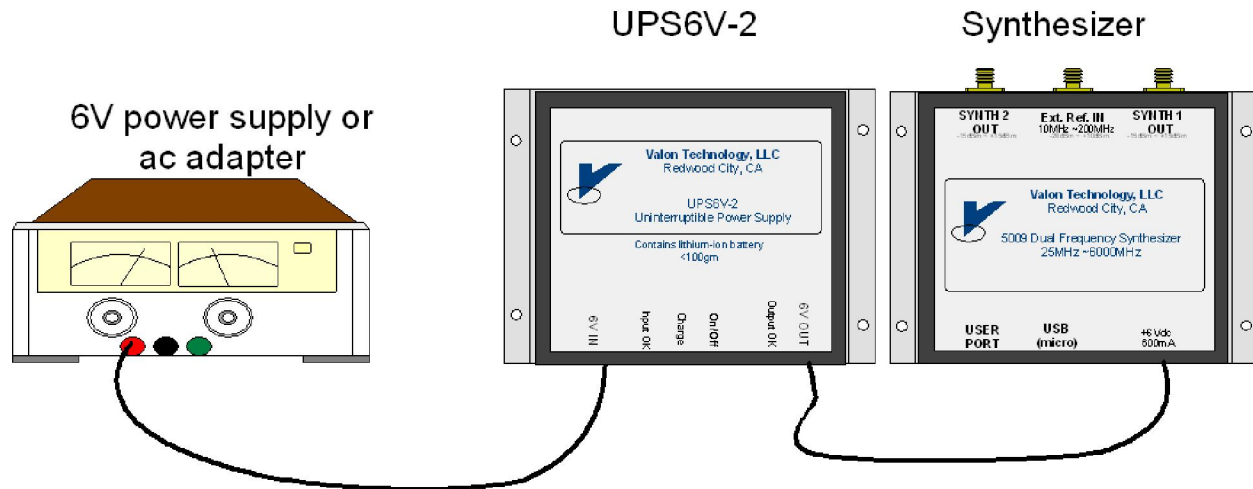

Figure 2 Typical Setup

Connect the UPS6V-2 to the 6V load (synthesizer typically) as shown in Figure 2 using the supplied double ended Hirose cable. The 6V OUT from the UPS6V-2 should be connected to the +6Vdc input of the synthesizer as shown.

Then connect the pig-tail end of the supplied Hirose cable to the power supply or ac adapter. Note that 2.1mm x 5.5mm barrel power plug adapter is available from Valon for connecting ac adapters to the pig-tail end of the Hirose power cable. Plug this cable into the UPS6V-2 and apply power from the power supply or ac adapter.

*PS6V-1 Power Supply Kit <http://www.valontechnology.com/accessories.html>*

**Let the power supply charge the battery completely before first use.**

Note that both the RED, GREEN, and BLUE LED should be illuminated. The Red LED indicated the battery is being charged and should extinguish once the battery is fully charged and the charger has entered the final constant voltage mode.

Once the battery is fully charged, the power supply can be switched off or disconnected. To turn the boost converter on and apply power to the load, press the push-button switch once. The BLUE LED should illuminate indicating that boost converter is working and supplying output power from the battery.

The power source can be re-applied at any time and the UPS6V-2 will automatically shut down the boost converter and start charging the battery as indicated by the GREEN and RED LEDs. The boost converter will automatically restart if the power source is disconnected or turned off.



## 6 Connectors, LEDs, and Switch

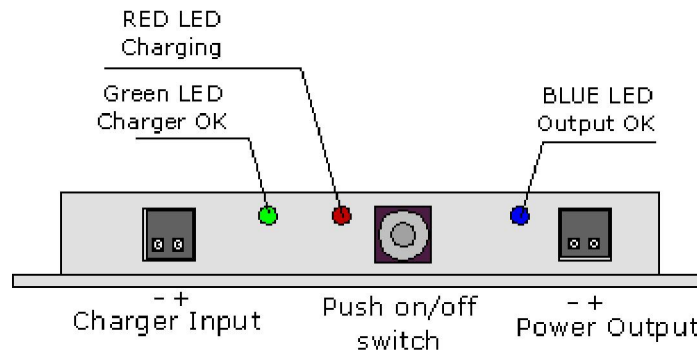

Figure 3 Connectors, LEDs, and push-button switch

- Charger input: Apply 6V dc to charge the battery and/or provide output power
- Green LED: Indicates proper input voltage is applied for charging. Note charging voltage can be lower than the required voltage for the certain 6V products.
- Red LED: On when battery is charging, off when the battery is fully charged.
- Push-button switch: Toggles the boost converter on and off.
- Blue LED: With no charger input, the blue LED will be on if the boost converter is cycled on with the push-button switch. With 6V input applied to the input connector, the blue LED will be on regardless of the last state of the boost converter.





## 7 Mechanical Dimensions

3.625"W x 2.685"L x 0.55"H

Weight: 0.2lbs, 91g

Material: AL-6061-T6

Finish: Clear Alodine (conductive)

